

## *Data Sheet*

Customer: \_\_\_\_\_

Product: Thick Film Chip Resistor. Triple Power Rating TPF Series \_\_\_\_\_

Size : 0603/0805/1206/2512 \_\_\_\_\_

Issued Date: 6-Jan.-2017 \_\_\_\_\_

Edition: Ver. 2 \_\_\_\_\_

### Record of change

Date	Ver.	Description	Page
6-Jan.-2017	1		
6-Mar.-2017	2	Add size 2512 3W	

## **HITANO ENTERPRISE CORP.**

7F-7, No. 3, Wu Chuan 1<sup>st</sup> Road, New Taipei Industrial Park,

New Taipei City, TAIWAN, R.O.C.

Tel: +886 2 2299 1331 (Rep.)

Fax: +886 2 2298 2466, 2298 2969

Prepared by	Checked by	Approved by	Accepted by (customer)
6-Jan.-2017	6-Jan.-2017	6-Jan.-2017	
<i>Andy Hsu</i>	<i>Hwa Wu</i>	<i>Hwa Wu</i>	

# THICK FILM CHIP RESISTORS TRIPLE POWER

# TPF SERIES

## ■ Features

- Triple power rating comparing to standard type.
- Suitable for lead free soldering.
- Compatible with flow and reflow soldering

## ■ Applications

- Power supply
- Digital meter, Consumer electronics.
- Industry control board.
- LED Lighting

## ■ Configuration

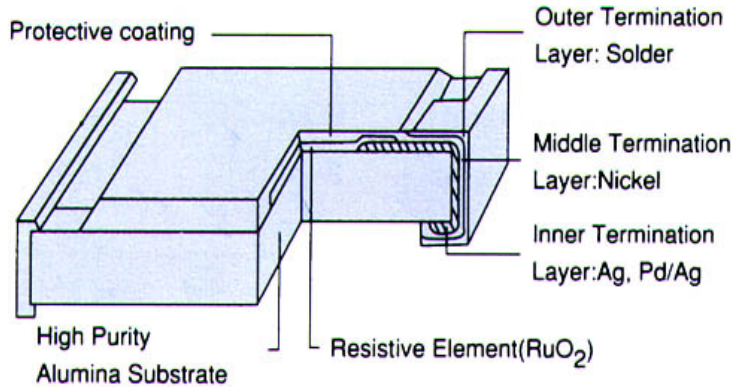

## ■ Dimensions

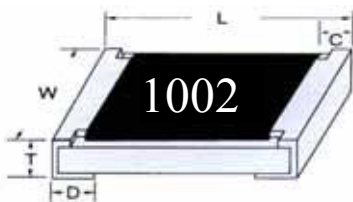

Size	L	W	C	D	T
0603	1.60±0.10	0.80±0.10	0.30±0.20	0.30±0.20	0.45±0.10
0805	2.00±0.10	1.25±0.10	0.40±0.20	0.40±0.20	0.50±0.10
1206	3.10±0.10	1.60±0.10	0.50±0.25	0.50±0.25	0.60±0.10
2512	6.40±0.20	3.10±0.20	0.45±0.25	1.80±0.25	1.10±0.20

Unit(mm)

## ■ Power Derating Curve

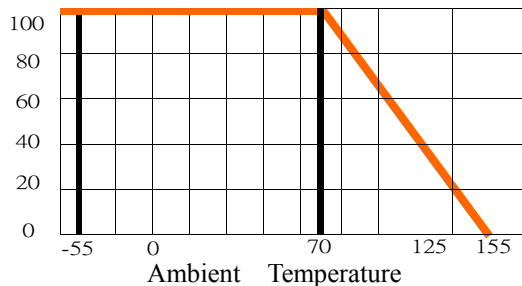

Maximum dissipation in percentage of rated power as a function of the ambient temperature for 0603,0805,1206

# THICK FILM CHIP RESISTORS TPF SERIES

## TRIPLE POWER

### Rating

Type	Size	Power Rating at 70°C	Max. RC WV	Max. Overload Voltage	Resistance Tolerance (%)	Temperature Coefficient (ppm/°C)	Resistance Range (Ω)		Standard Resistance Values
							Min.	Max.	
TPF0603	0603	1/3W	75V	125V	1	±100	10	1M	E96/E24
					1	±200	1	9.76	E96/E24
					5	±200	1	1M	E24
TPF0805	0805	1/2W	200V	300V	1	±100	10	1M	E96/E24
					1	±150	1	1M	E96/E24
					5	±200	1	9.76	E24
TPF1206	1206	3/4W	250V	500V	1	±100	1	1M	E96/E24
					5	±200	1	1M	E96
TPF2512	2512	3W	250V	500V	1	±100	1	1M	E96
					5	±200	10	1M	E24
TPF2512	2512	3W	1652mV	3695mV	1	±100	0.1	0.91	E24
					5	±200	0.1	0.91	E24

Note : (1) RCWV = (PxR)1/2 or Max. RCWV listed above, whichever is lower

RCWV: Working Voltage(V). P: Rated Power (W), R: Resistance Value(Ω)

(2) Solder-pad and trace size should be evaluated and board surface temperature should not exceed 105°C when applied full rated power.

(3) 2512 Solder-pad and trace size should be >300 mm<sup>2</sup> and board surface temperature should not exceed 105°C when applying full rated power.

### Soldering Temperature Curve

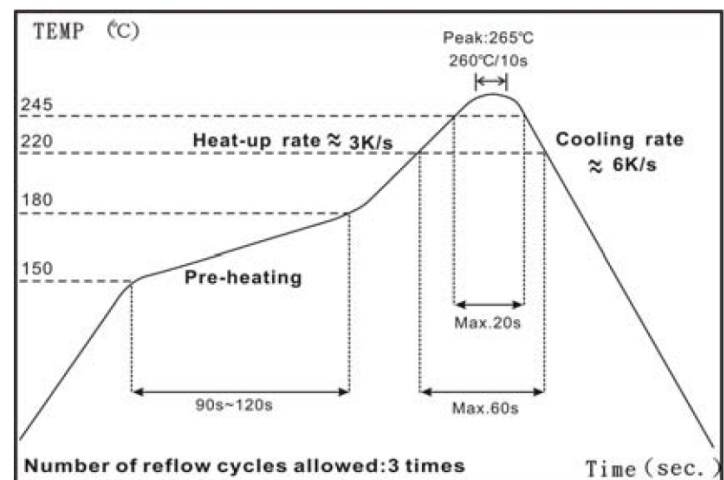
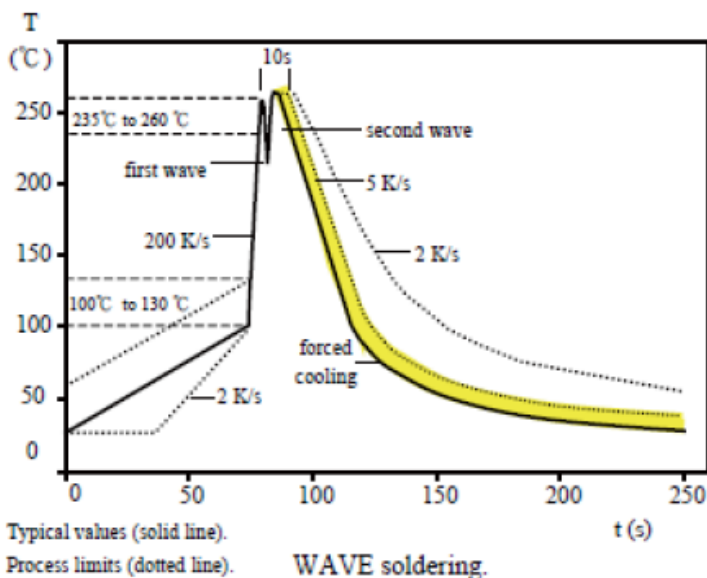

IR Reflow Soldering

# THICK FILM CHIP RESISTORS TPF SERIES

## TRIPLE POWER

### Recommended Solder Pad Dimension

Type	W	D	L
TPF0603	0.90	1.00	3.00
TPF0805	1.30	1.15	3.50
TPF1206	1.80	1.30	4.70
TPF2512	3.70	2.45	7.60

unit: (mm)

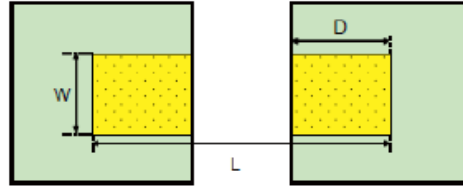

### Part Numbering

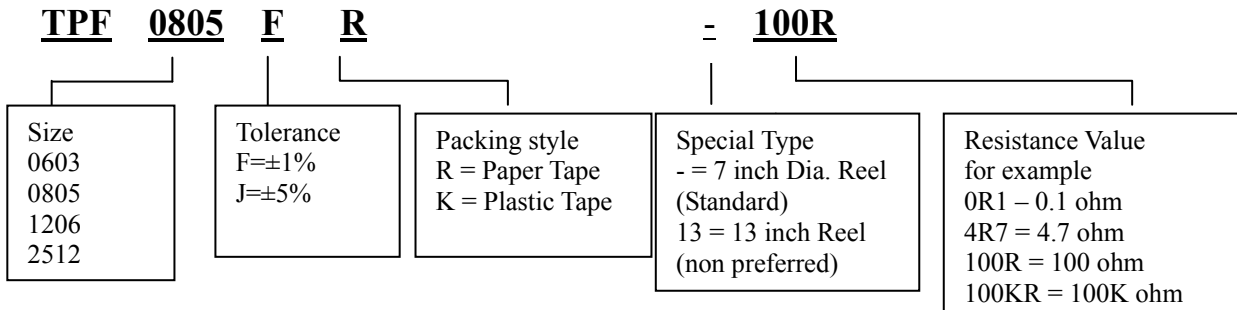

## GENERAL SPECIFICATION

### Resistance Marking



3 digit marking for E-24 ±5% 0603 0805 1206 2512  
example : **301**  $30 \times 10^1 = 300 \Omega$

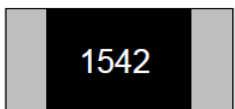

4 digit marking for E-24/E-96 ±1% 0805 1206 2512  
example : **1542**  $154 \times 10^2 = 15K4 \Omega$

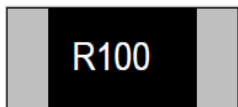

Below 1Ω E24 ±1%,±5% : 4 Digits marking to identify the resistance value  
example : R100=100mΩ · R390=390mΩ

# THICK FILM CHIP RESISTORS      TPF SERIES

## TRIPLE POWER

### ■ Tape And Reel Package

• Taping specs are according to EIA RS-481

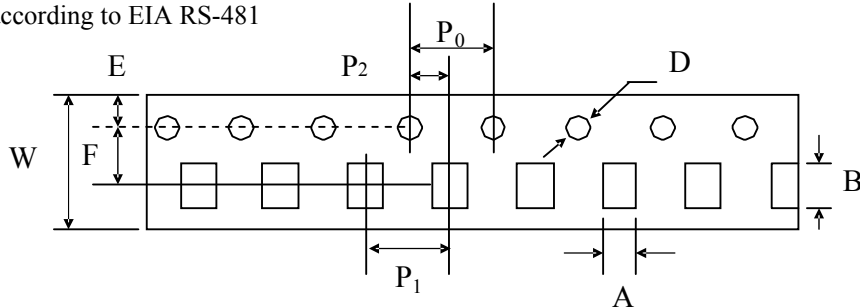

Accumulated dimensional tolerance  $40\pm 0.2\text{mm}$

Size	A	B	W	F	E	P1	P2	P0	D
0603	$1.10\pm 0.20$	$1.90\pm 0.20$	$8.00\pm 0.30$	$3.50\pm 0.05$	$1.75\pm 0.10$	$4.00\pm 0.10$	$2.00\pm 0.05$	$4.00\pm 0.10$	$1.50+0.10/-0$
0805	$1.65\pm 0.20$	$2.40\pm 0.20$	$8.00\pm 0.30$	$3.50\pm 0.05$	$1.75\pm 0.10$	$4.00\pm 0.10$	$2.00\pm 0.05$	$4.00\pm 0.10$	$1.50+0.10/-0$
1206	$2.00\pm 0.20$	$3.60\pm 0.20$	$8.00\pm 0.30$	$3.50\pm 0.05$	$1.75\pm 0.10$	$4.00\pm 0.10$	$2.00\pm 0.05$	$4.00\pm 0.10$	$1.50+0.10/-0$
2512	$3.50\pm 0.20$	$6.70\pm 0.20$	$12.00\pm 0.30$	$5.50\pm 0.05$	$1.75\pm 0.10$	$4.00\pm 0.10$	$2.00\pm 0.05$	$4.00\pm 0.10$	$1.50+0.10/-0$

(unit: mm)

### ■ Reel Package

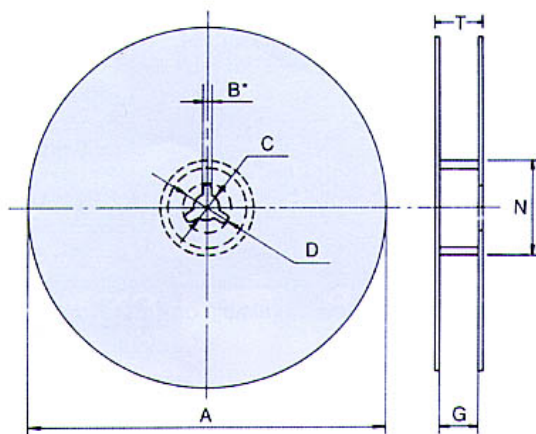

Size	Packaging Q'ty	A	N	C	D	B	G	T
0603	5Kpcs / Reel	$178.0\pm 2.0$	$60.0\pm 0.5$	$13.0\pm 0.5$	20min	$2.0\pm 0.5$	$10.0\pm 1.5$	14.9 max.
0805	20Kpcs / Reel	$330.0\pm 2.0$	$100.0\pm 1.0$	$13.5\pm 0.5$	20min	$2.0\pm 0.5$	$10.0\pm 1.5$	14.9 max.
1206								
2512	3Kpcs / Reel	$178.0\pm 2.0$	$60.0\pm 0.5$	$13.0\pm 0.5$	20min	$2.0\pm 0.5$	$10.0\pm 1.5$	14.9 max.

(unit: mm)

# THICK FILM CHIP RESISTORS      TPF SERIES

## TRIPLE POWER

### ■ HPF > 1Ω Specification And Test Methods

ITEM	SPECIFICATION	TEST METHOD
DC Resistance	J: $\pm 5\%$ , F: $\pm 1\%$	<b>IEC 60115-1 / JIS C 5201-1 , Clause 4.5</b> Measure the resistance value.
Short time Overload	J: $\Delta R \leq \pm (2\% + 0.5m\Omega)$ F: $\Delta R \leq \pm (1\% + 0.5m\Omega)$	<b>IEC 60115-1 / JIS C 5201-1 , Clause 4.13</b> 2.5×Rated voltage or Max. Overload Voltage for 5 sec. measure resistance after 30 minutes
Solderability	Over 95% of termination must be covered with solder	<b>IEC 60115-1 / JIS C 5201-1 , Clause 4.17</b> After immersing flux, dip in the $235\pm 2^{\circ}\text{C}$ molten solder bath for $2\pm 0.5$ sec.
Resistance to Solder Heat	J: $\Delta R \leq \pm (1\% + 0.5m\Omega)$ F: $\Delta R \leq \pm (0.5\% + 0.5m\Omega)$ No mechanical damage	<b>IEC 60115-1 / JIS C 5201-1 , Clause 4.18</b> With $260\pm 5^{\circ}\text{C}$ for $10\pm 1$ sec.
Temperature Coefficient (TCR)	As Spec.	<b>IEC 60115-1 / JIS C 5201-1 , Clause 4.8</b> $-55^{\circ}\text{C} \sim +125^{\circ}\text{C}$ , $25^{\circ}\text{C}$ is the reference temperature
Load Life Humidity	J: $\Delta R \leq \pm (3\% + 0.5m\Omega)$ F: $\Delta R \leq \pm (1\% + 0.5m\Omega)$	<b>IEC 60115-1 / JIS C 5201-1 , Clause 4.24</b> Maintain the temperature of the resistor at $40\pm 2^{\circ}\text{C}$ and 90 ~ 95% R.H. with the rated voltage applied. Cycle ON for 1.5 hours and OFF for 0.5 hour for $1000+48/-0$ hours. After 1~4 hour, measure
Load Life	J: $\Delta R \leq \pm (3\% + 0.5m\Omega)$ F: $\Delta R \leq \pm (1\% + 0.5m\Omega)$	<b>IEC 60115-1 / JIS C 5201-1 , Clause 4.25</b> Permanent resistance change after $1000+48/-0$ hours (1.5 hours ON , 0.5 hour OFF) at RCWV or Max. Keep the resistor at $70\pm 2^{\circ}\text{C}$ ambient
Temperature Cycle	J: $\Delta R \leq \pm (1\% + 1m\Omega)$ F: $\Delta R \leq \pm (0.5\% + 1m\Omega)$ No mechanical damage	<b>IEC 60115-1 / JIS C 5201-1 , Clause 4.19</b> Repeat 5 cycles as follows $-55^{\circ}\text{C}$ (30 min.) + $25^{\circ}\text{C}$ (2~3 min.) $+125^{\circ}\text{C}$ (30 min.) + $25^{\circ}\text{C}$ (2~3 min.) for 0201 $55^{\circ}\text{C}$ (30 min.) + $25^{\circ}\text{C}$ (2~3 min.) $+155^{\circ}\text{C}$ (30 min.) + $25^{\circ}\text{C}$ (2~3 min.) for others
Insulation Resistance	Between termination and coating must be over $1000M\Omega$	<b>IEC 60115-1 / JIS C 5201-1 , Clause 4.6</b> Test voltage: $100\pm 15\text{V}$
Bending Strength	J: $\Delta R \leq \pm (1\% + 1m\Omega)$ F: $\Delta R \leq \pm (0.5\% + 1m\Omega)$ No mechanical damage	<b>IEC 60115-1 / JIS C 5201-1 , Clause 4.33</b> Resistance change after bended on the 90mm PCB Bend: 3mm for 0603、0805 2mm for 1206、1210、2010、2512