

BAS16W THRU BAS21W

TECHNICAL SPECIFICATIONS OF SURFACE MOUNT SWITCHING DIODE

VOLTAGE RANGE - 75 to 200 Volts

CURRENT - 0.2 to 0.25 Ampere

FEATURES

- * Surface Mount Package Ideally Suited for Automatic Insertion
- * Low power loss, high efficiency
- * Low leakage
- * Low forward voltage
- * High current capability

MECHANICAL DATA

- * Case: Molded plastic
- * Epoxy: UL 94V-0 rate flame retardant
- * Terminals: Solder plated, solderable per MIL-STD-202E, Method 208 guaranteed
- * Mounting position: Any
- * Weight: 0.008 grams Approx.

MAXIMUM RATINGS AND ELECTRICAL CHARACTERISTICS

Ratings at 25°C ambient temperature unless otherwise specified. Single phase, half wave, 60 Hz, resistive or inductive load. For capacitive load, derate current by 20%.



SOT-323

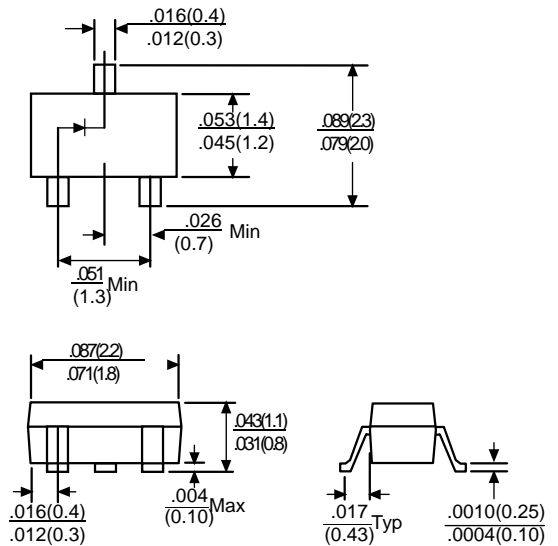

	SYMBOL	BAS16W	BAS19W	BAS20W	BAS21W	UNITS
Maximum Reverse Voltage	VR	75	100	150	200	V
Maximum Recurrent Peak Reverse Voltage	VRRM	100	120	200	250	V
Maximum Average Rectified Current	Io	250	200			mA
Peak Forward Surge Current, 8.3ms single half sine-wave superimposed on rated load (JEDEC Method)	IFSM	2.0	2.5			A
Maximum Power Dissipation Tamb=25°C	Ptot	200				mW
Maximum Forward Voltage (@IF=100mA)	VF	0.855(@IF=10mA)	1.0			V
Maximum Reverse Current (@VR=VR Max)	IR	1.0	0.1			µA
Maximum Reverse Recovery Time(Note 1)	trr	6.0	50			nS
Typical Junction Capacitance(Note 2)	CJ	2.0	1.5			pF
Typical Thermal Resistance	RθJA	357				°C/W
Operating and Storage Temperature Range	TJ,TSTG	-55 to +125				°C

Note: 1. Test Conditions: IF=IR=10mA, RL=100Ω, VR=6V to IR=1mA, RL=100Ω
 2. Measured at 1MHz and VR=0

RATING AND CHARACTERISTIC CURVES (BAS16W THRU BAS21W)

FIG.1 - TYPICAL INSTANTANEOUS FORWARD CHARACTERISTICS

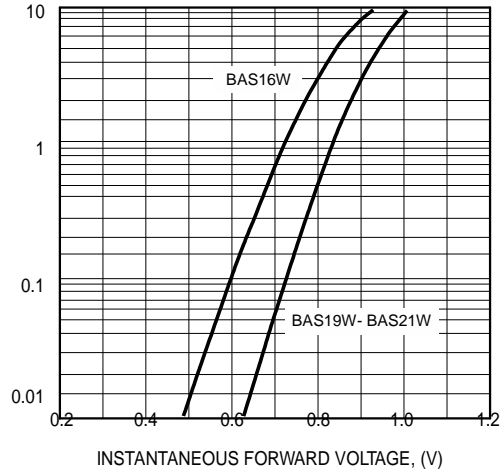

FIG.2 - TYPICAL REVERSE CHARACTERISTICS

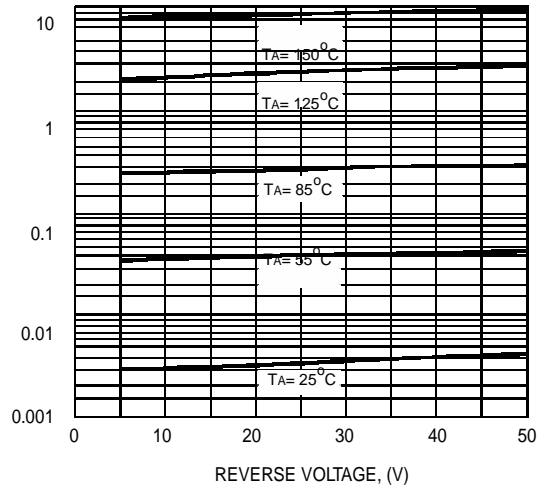

FIG.3 - TYPICAL JUNCTION CAPACITANCE

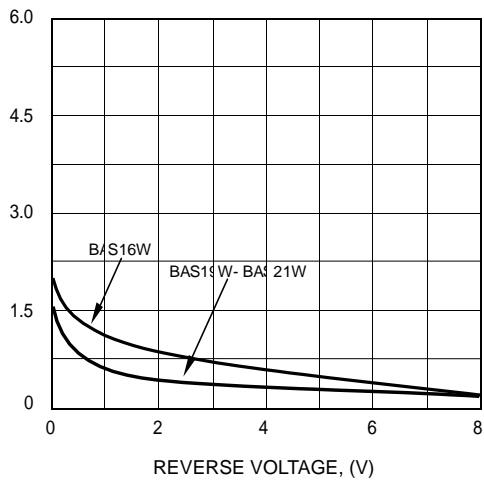

FIG.4 - RECTIFICATION EFFICIENCY MEASUREMENT CIRCUIT

