

SM5817S THRU SM5819S

TECHNICAL SPECIFICATIONS OF SURFACE MOUNT SCHOTTKY BARRIER RECTIFIER

VOLTAGE RANGE - 20 to 40 Volts

CURRENT - 1.0 Ampere

FEATURES

- * High current capability
- * Ideal for surface mounted applications
- * Low leakage current for high efficiency

MECHANICAL DATA

- * Case: Molded plastic
- * Epoxy: UL 94V-0 rate flame retardant
- * Terminals: Solder plated solderable per MIL-STD-202E, Method 208 guaranteed
- * Polarity: Color band denotes cathode end
- * Mounting position: Any
- * Weight: 0.036 gram

MAXIMUM RATINGS AND ELECTRICAL CHARACTERISTICS

Ratings at 25 °C ambient temperature unless otherwise specified.
Single phase, half wave, 60 Hz, resistive or inductive load.
For capacitive load, derate current by 20%.



SM-2(DO-213AA)

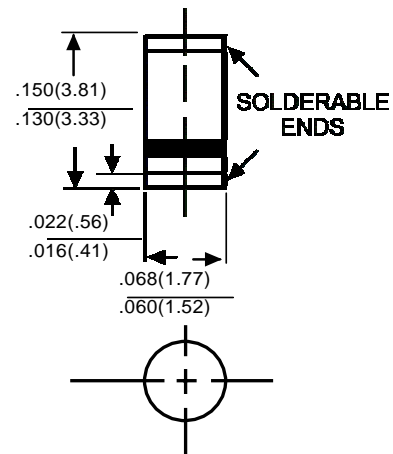

Dimensions in inches and (millimeters)

	SYMBOL	SM5817S	SM5818S	SM5819S	UNITS
Maximum Recurrent Peak Reverse Voltage	V_{RRM}	20	30	40	Volts
Maximum RMS Voltage	V_{RMS}	14	21	28	Volts
Maximum DC Blocking Voltage	V_{DC}	20	30	40	Volts
Maximum Average Forward Rectified Current at $T_A=90^\circ C$	I_O	1.0			Amps
Peak Forward Surge Current 8.3 ms single half sine-wave superimposed on rated load (JEDEC Method)	I_{FSM}	25			Amps
Maximum Instantaneous Forward Voltage at 1.0A DC	V_F	.50	.55	.60	Volts
Maximum DC Reverse Current at Rated DC Blocking Voltage	I_R	@ $T_A=25^\circ C$	1.0		mAmps
		@ $T_A=100^\circ C$	10		
Typical Thermal Resistance (Note1)	$R_{\theta JA}$	75			$^\circ C/w$
Typical Junction Capacitance (Note2)	C_J	110			pF
Storage Operating Temperature Range	T_J, T_{STG}	-65 to +125			$^\circ C$

NOTES: 1. Thermal Resistance (Junction to Ambient), .24in² (6.0mm²) copper pads to each terminal.
2. Measured at 1 MHz and applied reverse voltage of 4.0 volts.

RATING AND CHARACTERISTIC CURVES (SM5817S THRU SM5819S)

FIG. 1 - TYPICAL FORWARD CURRENT DERATING CURVE

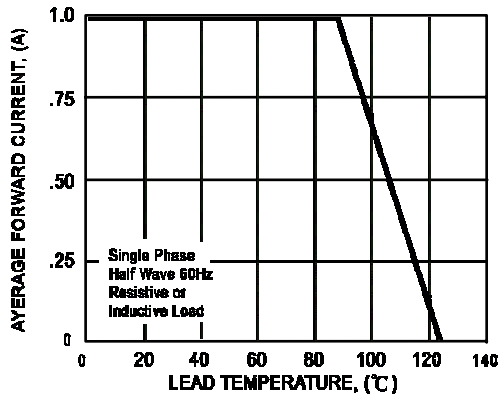

FIG. 2 - TYPICAL INSTANTANEOUS FORWARD CHARACTERISTICS

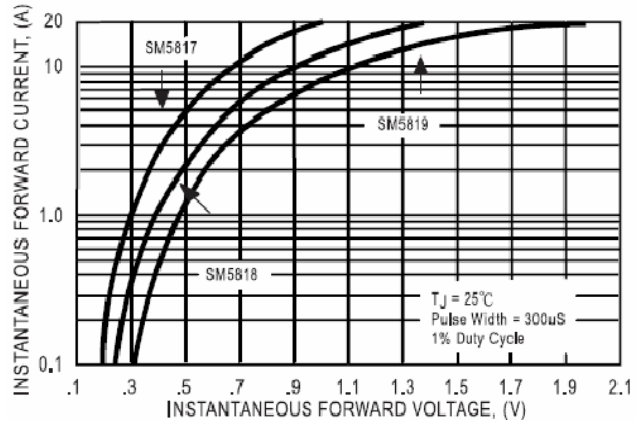

FIG. 3 - TYPICAL REVERSE CHARACTERISTICS

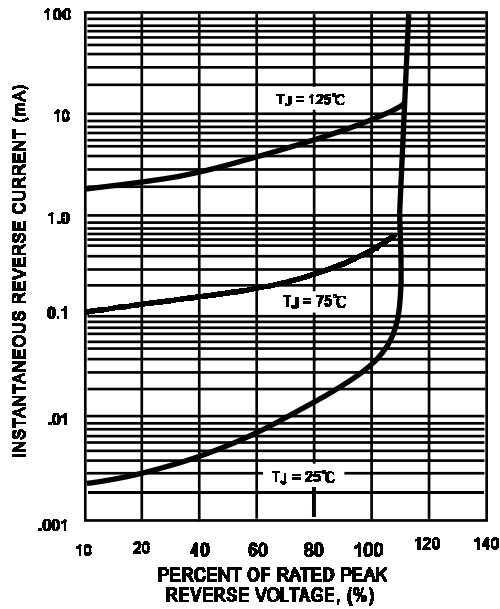

FIG. 4 - MAXIMUM NON-REPETITIVE FORWARD SURGE CURRENT

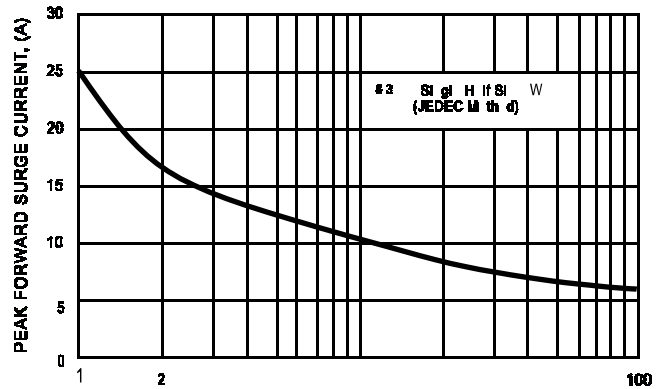

FIG. 5 - TYPICAL JUNCTION CAPACITANCE

