

**FR101G THRU FR107G**

**TECHNICAL SPECIFICATIONS OF FAST RECOVERY GLASS PASSIVATED RECTIFIER**  
**VOLTAGE RANGE - 50 to 1000 Volts** **CURRENT - 1.0 Ampere**

**FEATURES**

- \* High reliability
- \* Low leakage
- \* Low forward voltage drop
- \* High current capability
- \* High switching capability
- \* Glass passivated junction

**MECHANICAL DATA**

- \* Case: Molded plastic
- \* Epoxy: UL 94V-0 rate flame retardant
- \* Lead: MIL-STD-202E, Method 208 guaranteed
- \* Polarity: Color band denotes cathode end
- \* Mounting position: Any
- \* Weight: 0.33 gram

**MAXIMUM RATINGS AND ELECTRICAL CHARACTERISTICS**

Ratings at 25 °C ambient temperature unless otherwise specified.  
 Single phase, half wave, 60 Hz, resistive or inductive load.  
 For capacitive load, derate current by 20%.

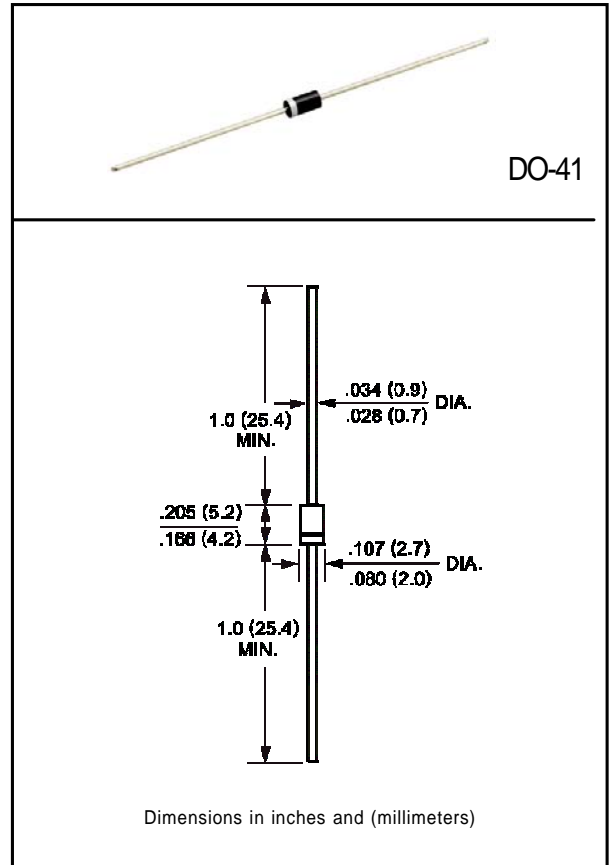

	SYMBOL	FR101G	FR102G	FR103G	FR104G	FR105G	FR106G	FR107G	UNITS
Maximum Recurrent Peak Reverse Voltage	V <sub>RRM</sub>	50	100	200	400	600	800	1000	Volts
Maximum RMS Voltage	V <sub>RMS</sub>	35	70	140	280	420	560	700	Volts
Maximum DC Blocking Voltage	V <sub>DC</sub>	50	100	200	400	600	800	1000	Volts
Maximum Average Forward Rectified Current at T <sub>A</sub> = 55°C	I <sub>O</sub>	1.0							Amps
Peak Forward Surge Current 8.3 ms single half sine-wave superimposed on rated load (JEDEC Method)	I <sub>FSM</sub>	30							Amps
Maximum Instantaneous Forward Voltage at 1.0A DC	V <sub>F</sub>	1.3							Volts
Maximum DC Reverse Current at Rated DC Blocking Voltage T <sub>A</sub> = 25°C	I <sub>R</sub>	5.0							uAmps
Maximum Full Load Reverse Current Average, Full Cycle .375*(9.5mm) lead length at T <sub>L</sub> = 55°C		100							uAmps
Maximum Reverse Recovery Time (Note 1)	t <sub>rr</sub>	150			250	500		nSec	
Typical Junction Capacitance (Note 2)	C <sub>J</sub>	15							pF
Operating and Storage Temperature Range	T <sub>J</sub> , T <sub>STG</sub>	-65 to + 150							°C

NOTES : 1. Test Conditions: I<sub>F</sub> = 0.5A, I<sub>R</sub> = 1.0A, I<sub>RR</sub> = 0.25A  
 2. Measured at 1 MHz and applied reverse voltage of 4.0 volts

# RATING AND CHARACTERISTIC CURVES ( FR101G THRU FR107G )

FIG. 1 - TEST CIRCUIT DIAGRAM AND REVERSE RECOVERY TIME CHARACTERISTIC

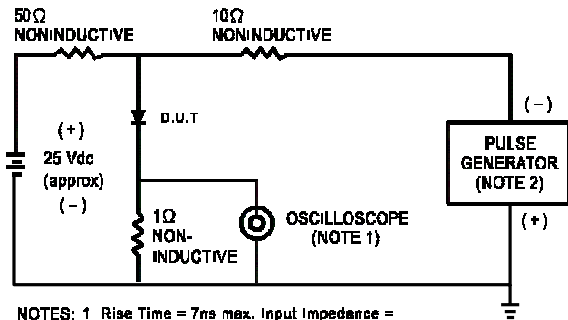

NOTES: 1. Rise Time = 7ns max. Input Impedance = 1 megohm. 22pF.  
 2. Rise Time = 10ns max. Source Impedance = 50 ohms.

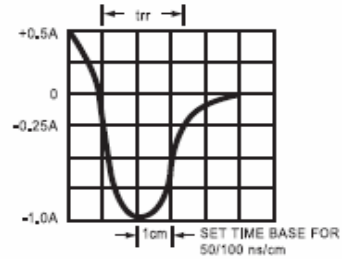

FIG. 1 - TYPICAL FORWARD CURRENT DERATING CURVE

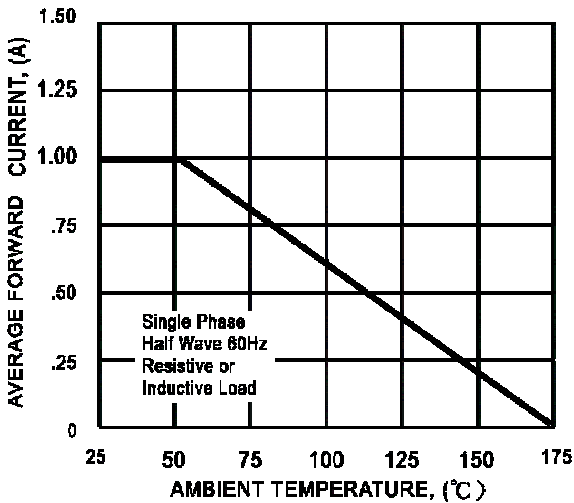

FIG. 3 - TYPICAL INSTANTANEOUS FORWARD CHARACTERISTICS

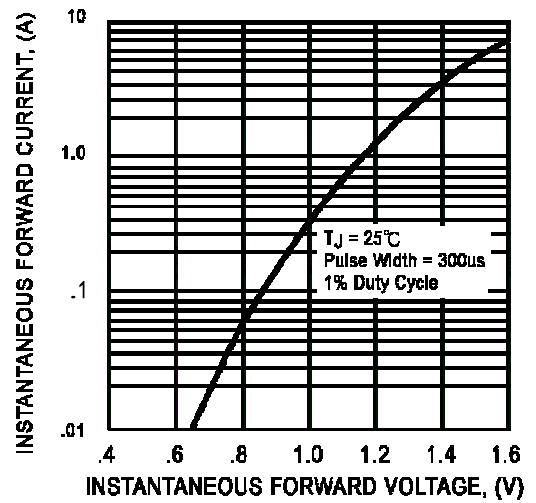

FIG. 4 - TYPICAL JUNCTION CAPACITANCE

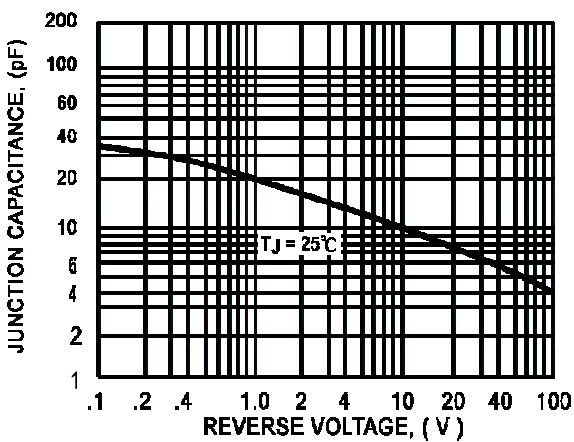

FIG. 3 - MAXIMUM NON-REPETITIVE FORWARD SURGE CURRENT

