

FR151-FR157

TECHNICAL SPECIFICATIONS OF FAST RECTIFIER VOLTAGE RANGE – 50 to 1000 Volts CURRENT – 1.5 Amperes

FEATURES

- *Fast switching
- *Low leakage
- *Low forward voltage drop
- *High current capability
- *High current surge
- *High reliability

MECHANICAL DATA

- *Case : Molded plastic
- *Epoxy : UL 94V-0 rate flame retardant
- *Lead : MIL-STD-202E , Method 208 guaranteed
- *Mounting position : Any
- *Weight : 0.38 gram

MAXIMUM RATINGS AND ELECTRICAL CHARACTERISTICS

Ratings at 25°C ambient temperature unless otherwise specified.

Single phase, half wave, 60 Hz , resistive or inductive load.

For capacitive load , derate current by 20%.

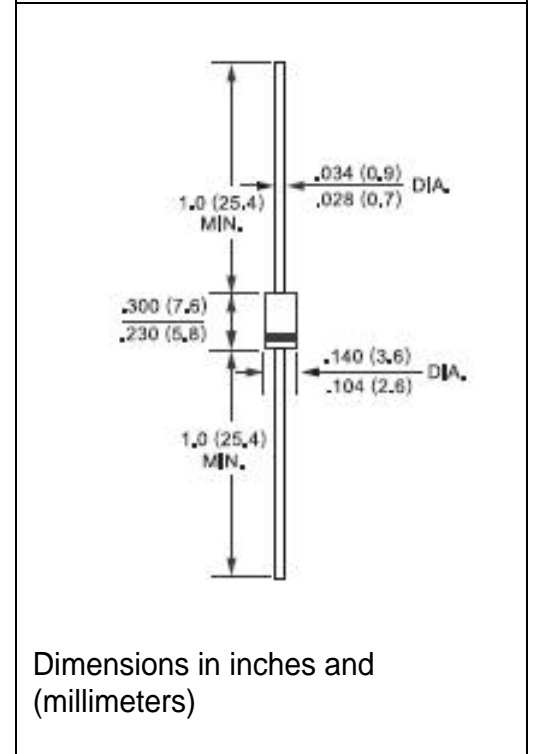

	SYMBOL	FR151	FR152	FR153	FR154	FR155	FR156	FR157	UNIT
Maximum Recurrent Peak Reverse Voltage	V_{RRM}	50	100	200	400	600	800	1000	Volts
Maximum RMS Voltage	V_{RMS}	35	70	140	280	420	560	700	Volts
Maximum DC Blocking Voltage	V_{DC}	50	100	200	400	600	800	1000	Volts
Maximum Average Forward Rectified Current At $T_A = 75^\circ C$	I_o	1.5							Amps
Peak Forward Surge Current 8.3 ms single half sine-wave superimposed on rated load (JEDEC Method)	I_{FSM}	60							Amps
Maximum instantaneous Forward Voltage at 1.5A DC	V_F	1.3							Volts
Maximum DC Reverse Current at Rated DC Blocking Voltage $T_A = 25^\circ C$	I_R	5.0							μA
Maximum Full Load Reverse Current Full Cycle Average, .375*(9.5mm) lead length at $T_L = 55^\circ C$		100							μA
Maximum Reverse Recovery Time (Note 1)	t_{rr}	150		250		500			nSec
Typical Junction Capacitance (Note 2)	C_J	40							pF
Operating and Storage Temperature Range	T_J, T_{STG}	-65 to +150							$^\circ C$

NOTES: 1. Test Conditions : $I_F = 0.5A$, $I_R = 1.0A$, $I_{RR} = 0.25A$

2. Measured at 1MHz and applied reverse voltage of 4.0 volts.

RATING AND CHARACTERISTIC CURVES (FR151 THRU FR157)

FIG. 1 - TYPICAL FORWARD CURRENT DERATING CURVE

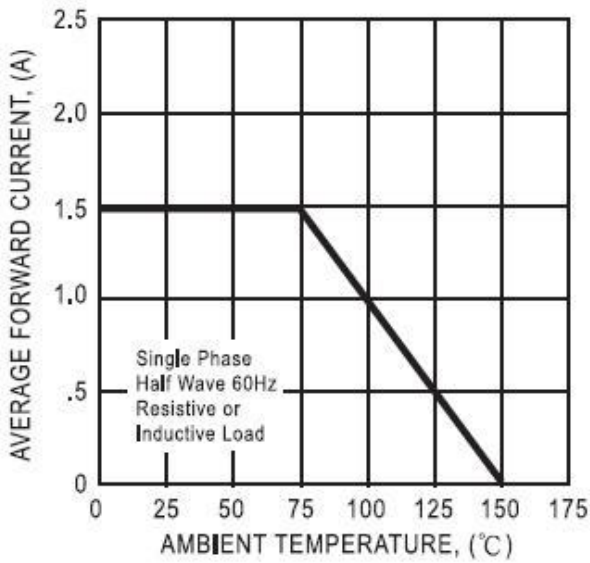

FIG. 2 - MAXIMUM NON-REPETITIVE FORWARD SURGE CURRENT

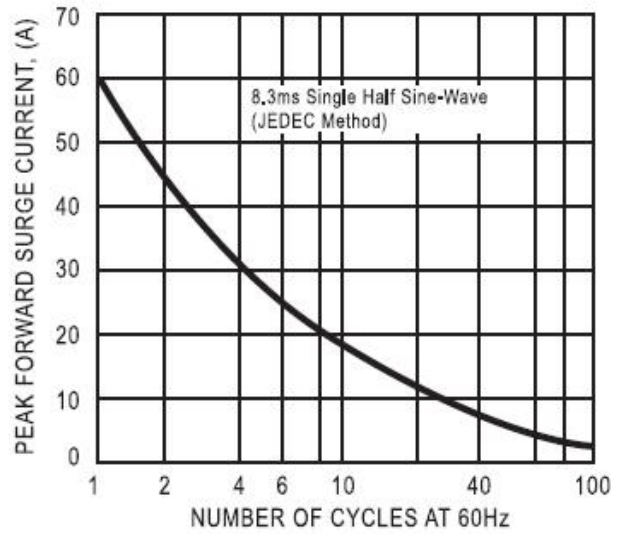

FIG. 3 - TYPICAL INSTANTANEOUS FORWARD CHARACTERISTICS

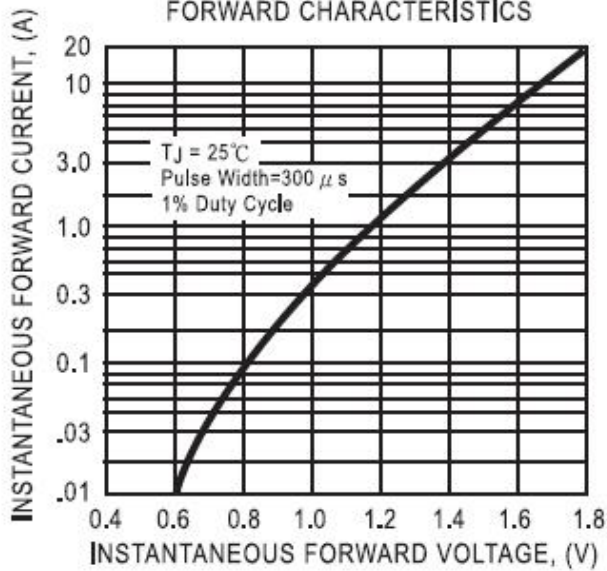

FIG. 4 - TYPICAL JUNCTION CAPACITANCE

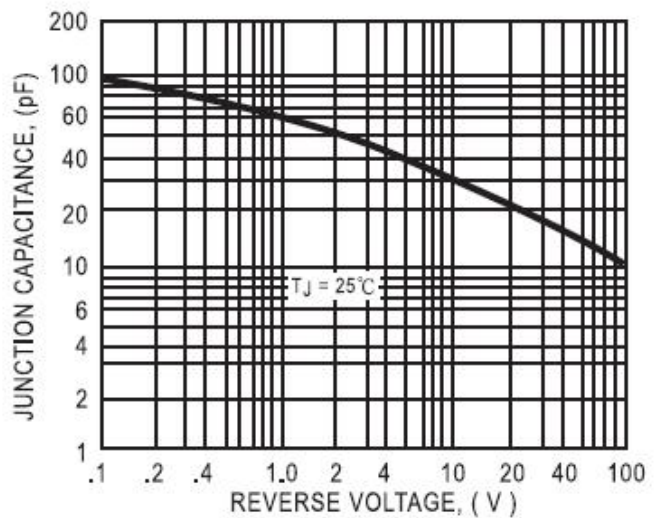
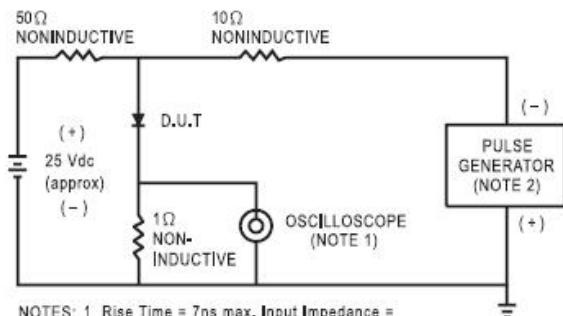

FIG. 5 - TEST CIRCUIT DIAGRAM AND REVERSE RECOVERY TIME CHARACTERISTIC



- NOTES: 1 Rise Time = 7ns max, Input Impedance = 1 megohm, 22pF.
2, Rise Time = 10ns max, Source Impedance = 50 ohms.

