

BZX84C2V4 THRU BZX84C39

TECHNICAL SPECIFICATIONS OF SURFACE MOUNT ZENER DIODES

FEATURES

- * Voltage Range: 2.4V to 39V
- * Ideally Suited for Automated Assembly Process
- * 410mW Power Dissipation

MECHANICAL DATA

- * Case: Molded plastic
- * Terminals: Solder plated, solderable per MIL-STD-202E, Method 208 guaranteed
- * Polarity: See Diagram
- * Mounting position: Any
- * Weight: 0.008 grams

MAXIMUM RATINGS AND ELECTRICAL CHARACTERISTICS

Ratings at 25°C ambient temperature unless otherwise specified.
Single phase, half wave, 60 Hz, resistive or inductive load.
For capacitive load, derate current by 20%.



SOT-23

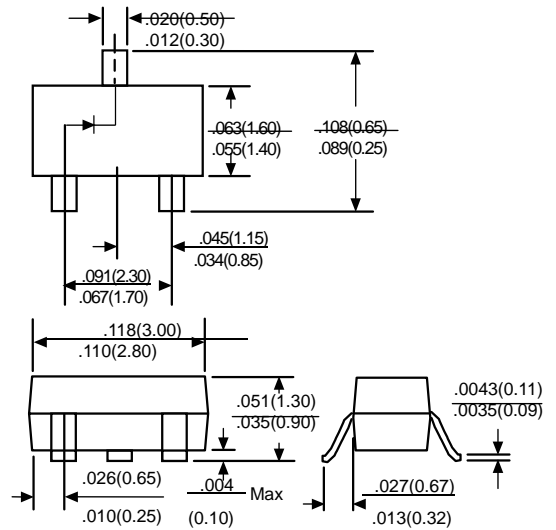

Dimensions in inches and (millimeters)

	SYMBOL	VALUE	UNITS
Zener Current see Table "Characteristics"			
Power Dissipation (Notes 1) at Tamb=25°C	Ptot	410	mW
Peak Forward Surge Current, 8.3ms single half sine-wave superimposed on rated load (JEDEC Method) (Notes 2)	IFSM	2.0	Amps
Maximum Forward Voltage at IF=100mA	VF	1.2	Volts
Operating and Storage Temperature	TJ, Tstg	-55 to + 150	°C

Notes: 1. Mounted on 5.0mm² (.013mm thick) land areas.
2. Measured on 8.3ms, single half sine-wave or equivalent square wave, duty cycle = 4 pulses per minute maximum.

RATING AND CHARACTERISTIC CURVES (BZX84C SERIES)

TYPE	Nominal Zener Voltage $V_Z @ I_{ZT}$		Zener Test Current I_{ZT}	Maximum Zener Impedance		I_{ZK}	Maximum Reverse Leakage Current		Typical Temperature Coefficient	Max. Zener Current $I_{ZM} @ I_A$	Marking Code
	Min	Max		$Z_{ZT} @ I_{ZT}$	$Z_{ZT} @ I_{ZK}$		$I_R @ V_R$				
			mA	Ohms	Ohms	mA	μA	Volts	% / °C	mA	
BZX84C2V4	2.28	2.56	5	85	600	1	100	1.0	-0.075	-	W1
BZX84C2V7	2.5	2.9	5	83	500	1	75	1.0	-0.065	134	W2
BZX84C3V0	2.8	3.2	5	95	500	1	50	1.0	-0.060	118	W3
BZX84C3V3	3.1	3.5	5	95	500	1	25	1.0	-0.055	109	W4
BZX84C3V6	3.4	3.8	5	95	500	1	15	1.0	-0.055	100	W5
BZX84C3V9	3.7	4.1	5	95	500	1	10	1.0	-0.050	92	W6
BZX84C4V3	4.0	4.6	5	95	500	1	5	1.0	-0.035	84	W7
BZX84C4V7	4.4	5.0	5	78	500	1	5	1.0	-0.015	76	W8
BZX84C5V1	4.8	5.4	5	60	480	1	0.1	0.8	+0.005	67	W9
BZX84C5V6	5.2	6.0	5	40	400	1	0.1	1.0	+0.020	59	WA
BZX84C6V2	5.8	6.6	5	10	200	1	0.1	2.0	+0.030	54	WB
BZX84C6V8	6.4	7.2	5	8	150	1	0.1	3.0	+0.045	49	WC
BZX84C7V5	7.0	7.9	5	7	50	1	0.1	5.0	+0.050	44	WD
BZX84C8V2	7.7	8.7	5	7	50	1	0.1	6.0	+0.055	40	WE
BZX84C9V1	8.5	9.6	5	10	50	1	0.1	7.0	+0.065	36	WF
BZX84C10	9.4	10.6	5	15	70	1	0.1	7.5	+0.070	33	WG
BZX84C11	10.4	11.6	5	20	70	1	0.1	8.5	+0.075	30	WH
BZX84C12	11.4	12.7	5	20	90	1	0.1	9.0	+0.080	28	WI
BZX84C13	12.4	14.1	5	25	110	1	0.1	10	+0.080	25	WK
BZX84C15	13.8	15.6	5	30	110	1	0.1	11	+0.090	23	WL
BZX84C16	15.3	17.1	5	40	170	1	0.1	12	+0.090	20	WM
BZX84C18	16.8	19.1	5	50	170	1	0.1	14	+0.090	18	WN
BZX84C20	18.8	21.2	5	50	220	1	0.1	15	+0.090	17	WO
BZX84C22	20.8	23.3	5	55	220	1	0.1	17	+0.090	16	WP
BZX84C24	22.8	25.6	5	80	220	1	0.1	18	+0.090	13	WR
BZX84C27	25.1	28.9	2	80	250	1	0.1	20	+0.090	12	WS
BZX84C30	28	32	2	80	250	1	0.1	22.5	+0.090	10	WT
BZX84C33	31	35	2	80	250	1	0.1	25	+0.090	9	WU
BZX84C36	34	38	2	90	250	1	0.1	27	+0.090	9	WW
BZX84C39	37	41	2	90	300	1	0.1	29	+0.110	8	WX

NOTE: Standard Zener Voltage Tolerance $\pm 5\%$

Breakdown characteristics

BZX84-SERIES

