

1N5221B THRU 1N5259B

TECHNICAL SPECIFICATIONS OF GLASS SILICON ZENER DIODES

FEATURES

- * Voltage Range: 2.4V to 39V
- * Double slug type construction

MECHANICAL DATA

- * Case: Glass sealed case
- * Lead: MIL-STD-202E, Method 208 guaranteed
- * Polarity: Color band denotes cathode end
- * Mounting position: Any
- * Weight: 0.13 gram

MAXIMUM RATINGS AND ELECTRICAL CHARACTERISTICS

Ratings at 25 °C ambient temperature unless otherwise specified.

Single phase, half wave, 60 Hz, resistive or inductive load.

For capacitive load, derate current by 20%.

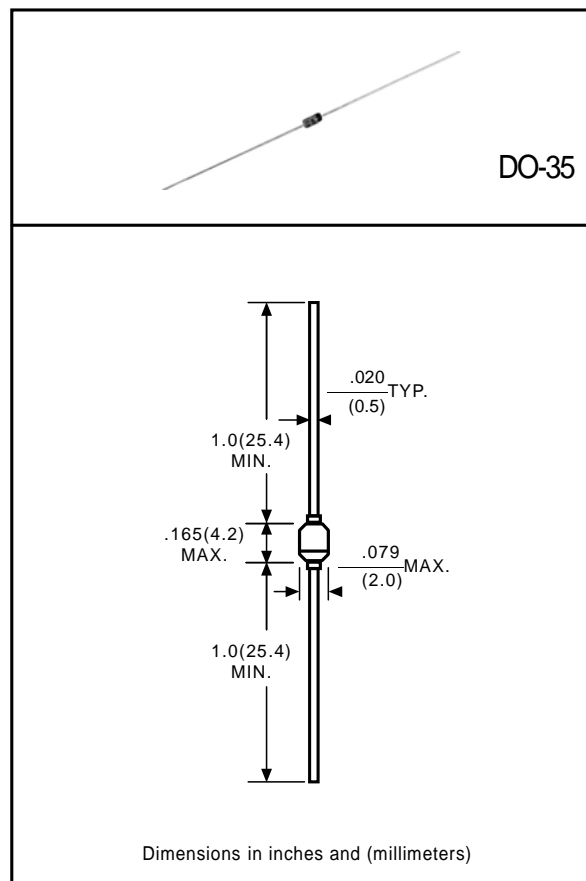

	SYMBOL	VALUE	UNITS
Zener Current see Table "Characteristics"			
Power Dissipation at Tamb=25°C	P _{tot}	500 ⁽¹⁾	mW
Junction Temperature	T _j	175	°C
Storage Temperature Range	T _{stg}	-55 to + 175	°C
Thermal Resistance	R _{thA}	-	K/mW
Junction to Ambient Air		-	Typ.
		0.3 ⁽¹⁾	Min.
			Max.
Forward Voltage	V _F	-	Volts
at I _F =100mA		-	Typ.
		1	Min.
			Max.

1)Valid Provided that leads are kept at ambient temperature at a distance of 8 mm from case.

NOTE: Suffix "B" indicates Zener Voltage Tolerance ± 5%

RATING AND CHARACTERISTIC CURVES (1N5221B THRU 1N5259B)

TYPE	Nominal Zener Voltage VZ@IZT	Zener Test Current IZT	Maximum Zener Impedance		Typical Temperature Coefficient % / °C	Maximum Reverse Leakage Current		Maximum Regulator Current IZM
			ZZT@IZT	ZZT@IZK()		IR	@VR	
			Ohms	Ohms.		uA	Volts	
1N5221B	2.4	20	30	1200	-0.085	100	1.0	191
1N5222B	2.5	20	30	1250	-0.085	100	1.0	182
1N5223B	2.7	20	30	1300	-0.080	75	1.0	168
1N5224B	2.8	20	30	1400	-0.080	75	1.0	162
1N5225B	3.0	20	29	1600	+0.075	50	1.0	151
1N5226B	3.3	20	28	1600	-0.070	25	1.0	138
1N5227B	3.6	20	24	1700	-0.065	15	1.0	126
1N5228B	3.9	20	23	1900	-0.060	10	1.0	115
1N5229B	4.3	20	22	2000	±0.055	5.0	1.0	106
1N5230B	4.7	20	19	1900	±0.030	5.0	2.0	97
1N5231B	5.1	20	17	1600	±0.030	5.0	2.0	89
1N5232B	5.6	20	11	1600	+0.038	5.0	3.0	81
1N5233B	6.0	20	7	1600	+0.038	5.0	3.5	76
1N5234B	6.2	20	7	1000	+0.045	5.0	4.0	73
1N5235B	6.8	20	5	750	+0.050	3.0	5.0	67
1N5236B	7.5	20	6	500	+0.058	3.0	6.0	61
1N5237B	8.2	20	8	500	+0.062	3.0	6.5	55
1N5238B	8.7	20	8	600	+0.065	3.0	6.5	52
1N5239B	9.1	20	10	600	+0.068	3.0	7.0	50
1N5240B	10	20	17	600	+0.075	3.0	8.0	45
1N5241B	11	20	22	600	+0.076	2.0	8.4	41
1N5242B	12	20	30	600	+0.077	1.0	9.1	38
1N5243B	13	9.5	13	600	+0.079	0.5	9.9	35
1N5244B	14	9.0	15	600	+0.082	0.1	10	32
1N5245B	15	8.5	16	600	+0.082	0.1	11	30
1N5246B	16	7.8	17	600	+0.083	0.1	12	28
1N5247B	17	7.4	19	600	+0.084	0.1	13	27
1N5248B	18	7.0	21	600	+0.085	0.1	14	25
1N5249B	19	6.6	23	600	+0.085	0.1	14	24
1N5250B	20	6.2	25	600	+0.086	0.1	15	23
1N5251B	22	5.6	29	600	+0.087	0.1	17	21.2
1N5252B	24	5.2	33	600	+0.088	0.1	18	19.1
1N5253B	25	5.0	35	600	+0.089	0.1	19	18.2
1N5254B	27	4.6	41	600	+0.090	0.1	21	16.8
1N5255B	28	4.5	44	600	+0.091	0.1	21	16.2
1N5256B	30	4.2	49	600	+0.091	0.1	23	15.1
1N5257B	33	3.8	58	700	+0.092	0.1	25	13.8
1N5258B	36	3.4	70	700	+0.093	0.1	27	12.6
1N5259B	39	3.2	80	800	+0.094	0.1	30	11.5

(*) Izk=0.25mA

Breakdown characteristics

1N52-SERIES

